

Current Collection Systems

for Catenary Dependent Vehicles

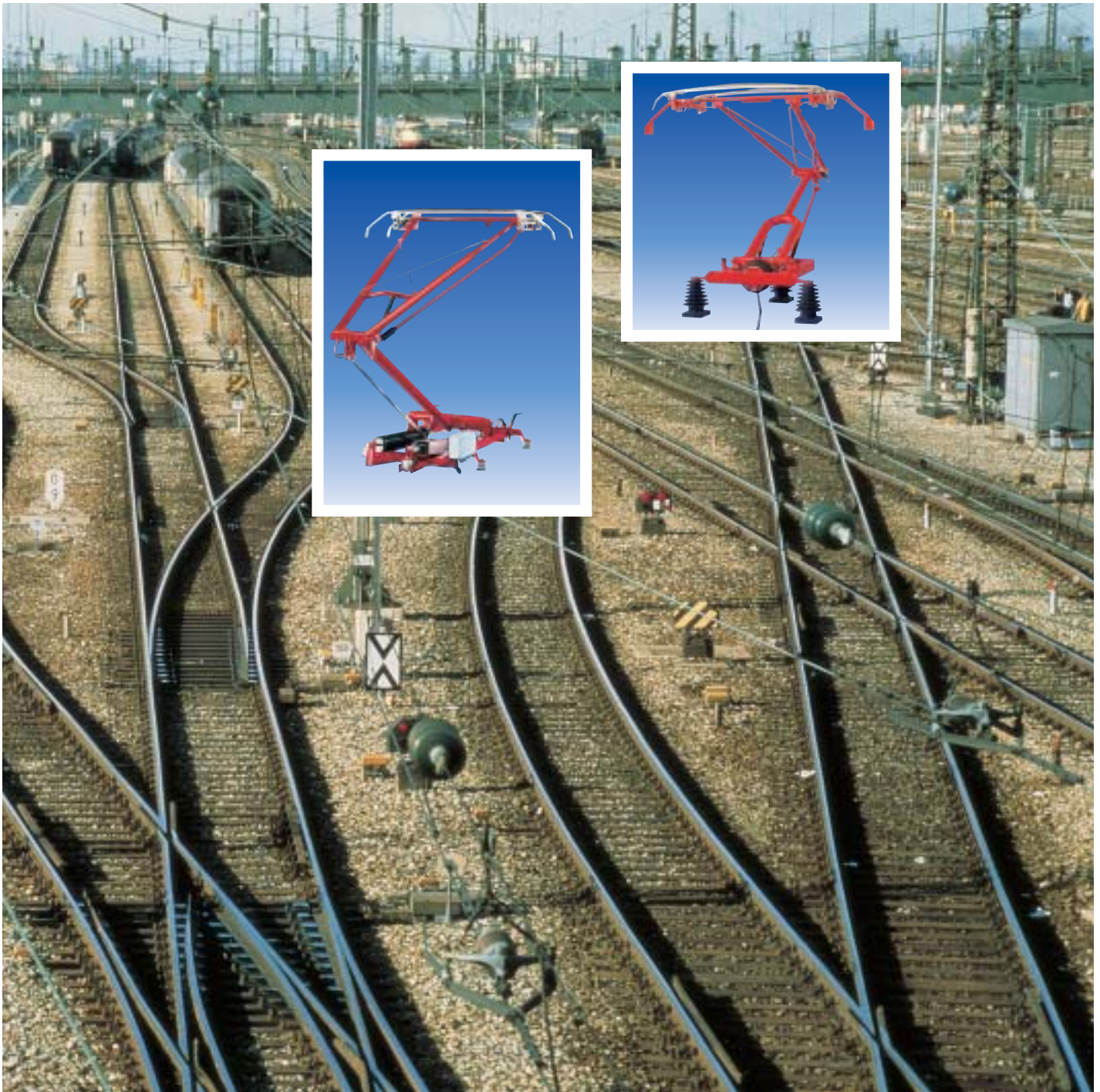

10.04 e/2000

Schunk Bahntechnik GmbH



Index

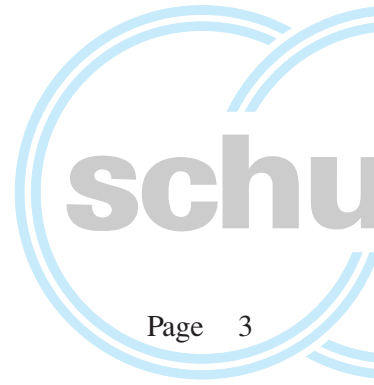

Introduction of SBT (Schunk Bahntechnik GmbH)	Page 3
Pantograph – Type WBR	Page 4
Pantograph – Type SBE	Page 5
Pantograph – Type SBL	Page 6
Pantograph – Type WBL	Page 7
SBT's – ABCS (Adhesive Bonded Carbon Strip)	Page 8
Carbon and Socket Profiles	Page 9
ABCS (Adhesive Bonded Carbon Strip) with Compressed Air Monitor	Page 10
Pantograph Contact Pressure Gauge – Type KM 11	Page 11

Introduction of Schunk Bahntechnik (SBT)



More than 50 years ago, Karl Wanisch, the founder of this company, started the business with the production of carbon strips for electrically operated vehicles. A few years later he expanded the product line of his company ETK – (Eisenbahntechnische Konstruktionen GmbH), Salzburg, Austria, by adding the manufacturing of complete pantograph systems. Today both – carbon strips and pantographs – receive industry recognition with European and global transit companies through new innovative technical concepts, quality, and customer oriented service.

Early in 1987 ETK was acquired by the Schunk Organization, and integrated into it's group of companies. The traditional philosophies nonetheless continue under the new name of SBT (Schunk Bahntechnik GmbH). However the union with Schunk opened a broader base for research and development, design possibilities, and worldwide distribution of it's ever expanding products.

During the last few years SBT has worked hard to optimize the power collection systems under high speed conditions. Our leading technical concept has proven it's reliability with many high speed transit companies, and established our company as a specialist in the industry.

The experience which SBT had gained from the high speed traction, has successfully transferred to the Commuter and Light Rail pantograph systems, which enabled Schunk to get well established in those segments as a technical market leader.

In addition to complete pantograph systems, SBT offers – in cooperation with SKT (Schunk Kohlenstofftechnik GmbH) – carbon current collector strips for all operating conditions of a modern transit company. With this product Schunk entered into new technologies and created a light weight current collector strip. This improved technology provides even carbon wear and drastically improved carbon strip service life.

The engineering of all pantographs is centrally conducted through SBT in Salzburg, Austria. Additional manufacturing will take place worldwide at the following companies:

- Schunk Nordiska, Lenhovda, Sweden, for the Scandinavian market
- Schunk Iberica, Madrid, Spain, for Spain and Portugal
- UKM, Kulpville, PA, USA, for the north-american market
- A new production for pantographs presently is set up in China
- Richard AG, Murgenthal, Switzerland, for Switzerland

The exact addresses can be found at the back of this brochure.

Schunk Bahntechnik is DIN ISO 9001/EN 29001 certified since 1995. All our pantographs conform to Standards EN 50206 and IEC 494.

Pantograph WBR

The WBR is a single-arm pantograph of lightweight, low maintenance construction. It was designed to operate under light rail and street car conditions. In spite of its strong lateral stability, which is comparable to the stability of the heavy rail pantographs, the WBR only exhibits a total weight of 293 lbs. (133 kg).

An oscillation damper has been integrated between the upper and lower frames, which optimizes the dynamic operational behavior of the pantograph.

Dependent on customers specifications, the pantograph can be lowered by a base mounted or roof mounted electrical drive, pneumatic air cylinder, or manually with a rope.

Extended reach WBR pantographs are available for the US market. The additional mass of these pantographs may increase the total assembly weight.

Special features of the WBR pantograph:

- strong lateral stability
- individual suspension of carbon strips (flat springs)
- low total weight
- easy maintenance
- hydraulic damping of fame
- sealed ball bearings
- emergency activation through manual hand crank possible
- optional: Shear Pin Safety System



Technical Data:

Height in resting position: – dependent on dimension of insulator 11.6" (295 mm)	Voltage: 600 V – 3000 V
Length in resting position: 97.1" (2465 mm)	Current: peak 2000 A nominal 1000 A
Max. reach over resting position: 100.2" (2545 mm)	Contact pressure: adjustable from 11.25 – 31.5 lbs. (50 – 140 N)
Total weight: – without insulators 293 lbs. (133 kg)	

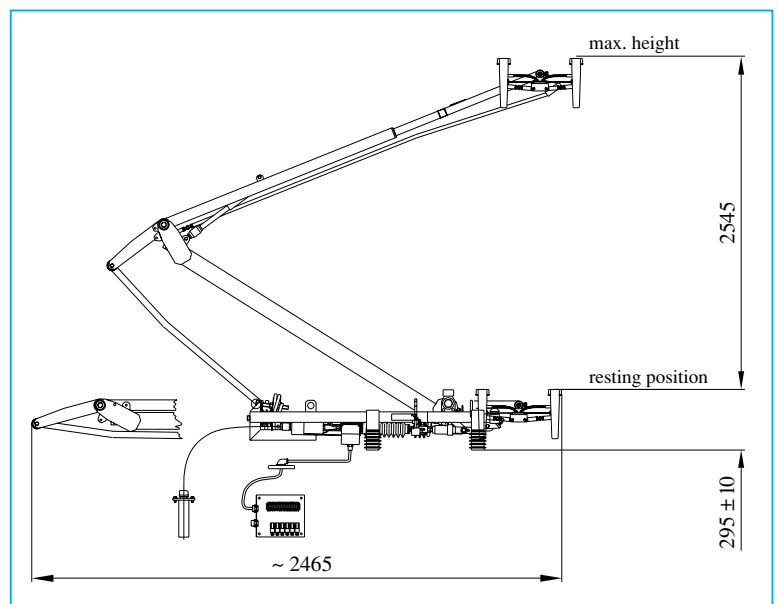

Pantograph

SBE

The SBE is a single-arm pantograph with an electrically insulated drive motor integrated into the base frame of the pantograph. This arrangement and the proven design present a light weight, easy to maintain, and simplistic pantograph. It is especially suited for light rail and trolley vehicle applications.

Special features of the SBE pantograph:

- strong lateral stability
- individual suspension of carbon strips – (flat springs) assuring good contact behavior
- low total weight
- easy maintenance
- hydraulic damping of fame
- electrically insulated drive motor
- emergency activation through crank handle possible
- lock in device in resting position possible



Technical Data:

Height in resting position: – dependent on dimension of insulator 11.8" (300 mm)	Voltage: 750 V DC – 1500 V DC
Length in resting position: 89.8" (2280 mm)	Current: peak 1800 A nominal 1000 A
Max. reach over resting position: 110.2" (2800 mm) – 116.1" (2950 mm)	Contact pressure: adjustable from 9.1 – 34.1 lbs. (40 – 150 N)
Total weight: – without insulators 275 lbs. (125 kg)	Drive voltage – optional: 24 V DC, 36 V DC, 48 V DC, 110 V DC
	Optional: automatic lowering system

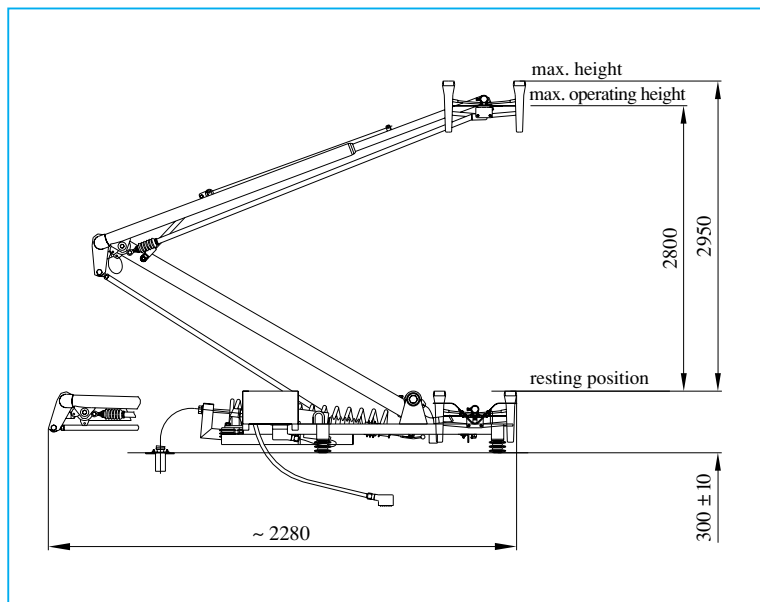

Pantograph SBL

The SBL is a single-arm pantograph of uncomplicated design, a low total weight, and suitable for light rail and trolley vehicles.

By using a pneumatic bellows drive system, one can relinquish the lifting springs and the spring retention cylinder. The adjustment of the contact pressure is accomplished through a precision pressure-regulating valve. This regulating valve can be mounted to the base frame of the pantograph, or into the vehicle itself.

Features of the SBE pantograph:

- strong lateral stability
- individual suspension of carbon strips – assuring good contact behavior
- low total weight
- easy maintenance
- hydraulic damping of fame



Technical Data:

Height in resting position: – dependent on dimension of insulator 13.8" (350 mm)	Voltage: 750 V DC – 1500 V DC
Length in resting position: 90.8" (2305 mm)	Current: peak 1800 A nominal 1000 A
Max. reach over resting position: 102.4" (2600 mm)	Contact pressure: adjustable from 11.25 – 31.5 lbs. (50 – 140 N)
Total weight: – without insulators 238 lbs. (108 kg)	Optional: automatic lowering system

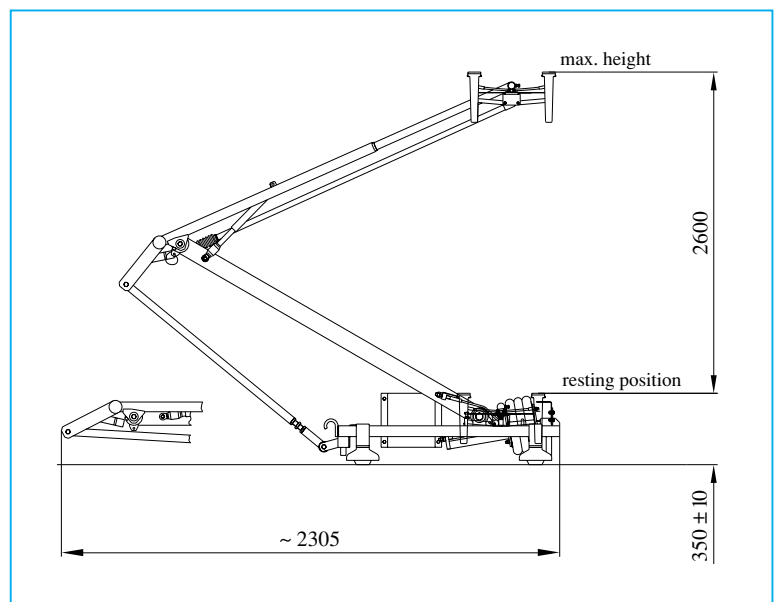

Pantograph WBL

The WBL has been designed for the highest speed conditions. During test drives of nearly 187.5 m/h (300 km/h) it has proven its excellent running features. Through constructive means an optimal aerodynamic behavior was obtained, independent of the driving direction. The pantograph WBL has a very simple drive system, which allows it to be extremely light weight and easy to maintain.

Dependent on customer specifications or area of application, the pantograph can be manufactured in different materials.

Features of the WBL pantograph:

- through integrated pneumatic suspension – low total weight
- individual suspension of carbon strips
- pan head guidance with dampened center of rotation
- hydraulic damping of fame
- easy maintenance
- optional installation of fast lowering device possible



Technical Data:

Height in resting position: – dependent on dimension of insulator 23.6" (600 mm)	Voltage: 600 V – 25 kV
Length in resting position: 92.9" (2360 mm)	Current: peak 2000 A nominal 1000 A
Max. reach over resting position: 96.9" (2460 mm)	Contact pressure: adjustable from 11.25 – 36.5 lbs. (50 – 160 N)
Total weight: – without insulators 264 lbs. (120 kg)	Suitable for speeds: up to 187.5 m/h (300 km/h)

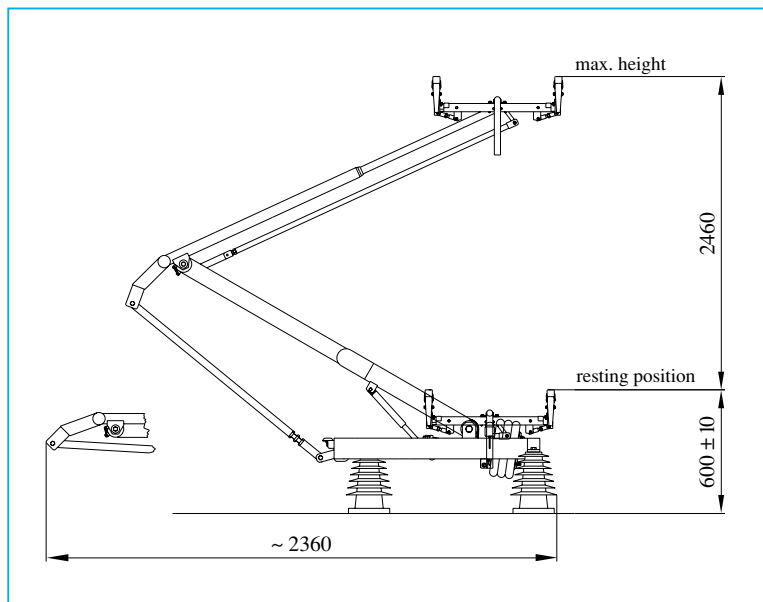

SBT's – ABCS (Adhesive Bonded Carbon Strip)

SBT is specialized for many years in the production of ABCS (adhesive bonded carbon strips). They optimized this technology to such an advanced level that those carbon strips can today be employed in all current systems. Following the advantages of the adhesive bonding technique versus all other bonding procedures:

- superior mechanical strength, when compared to the clamped version of carbon strip; with that reduced susceptibility to breakage
- the use of aluminum as socket material allows for a drastic weight reduction, when compared to sockets made of copper or steel
- more favorable manufacturing costs than with soldered carbon strips

- higher thermal resistance and better current carrying capacity
- due to the tough but elastic bond between carbon and socket, excellent fatigue strength, up to the highest frequencies of vibration

Principle

The carbon profile is permanently bonded to the aluminum socket by means of a special adhesive compound. An electrical contact strip between the two bonding points ensures that current flows freely from the carbon to the socket. Advantages of this arrangement are protection of the electrical contact points from hostile environment, thus avoiding oxidation, and due to the insulation of the adhesive bonding a reduction of arcing, when compared to conventional collector strips.

Applications and Grades

SBT's adhesive bonded carbon strips can be employed in DC and AC applications. The adaptation to the prevalent current occurs through either the carbon grade or the width, respectively the number of the carbon strips utilized.

- hard carbon up to currents of 600 A
- metal impregnated hard carbon for higher currents

Standard Profiles of Sockets and Carbon

Basically, SBT adhesive bonded carbon strips can replace any prevalent or commonly used carbon strip. Following we introduce some of the designs. The carbon profiles and sockets shown can be bonded to be straight, or they can be manufactured with a radius design of 6000 mm (236") or 10,000 mm (394"). The standard length is between 600 mm (23.6") and 1300 mm (51.2").

If you have any question, please contact us to help you select the most suitable system.

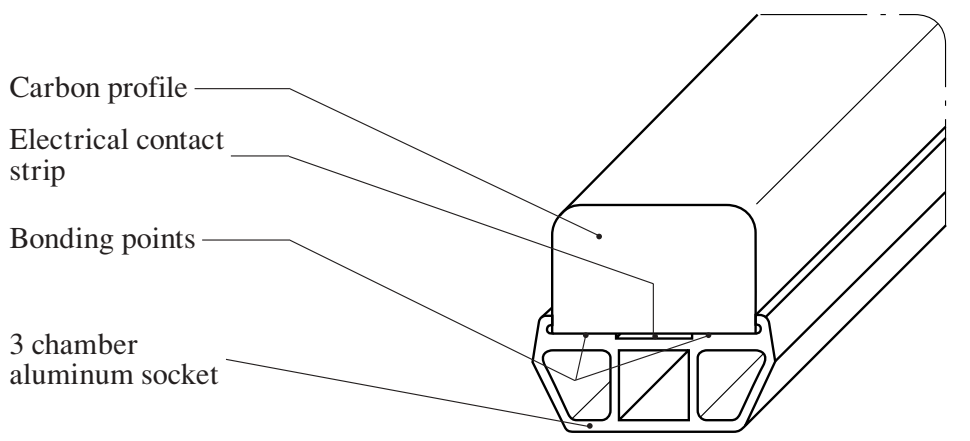

Carbon and Socket Profiles

Carbon Profile	Socket Profile	Weight Socket kg/m	Weight BH424 kg/m	Weight BH424C kg/m	Availability of Radius mm
020	1746	0.6	1.2	2.0	none
020 a	1746	0.6	1.1	1.8	none
444	1744	0.7	1.7	2.8	none, 6000, 10,000
414	1744	0.7	2.0	3.2	none, 6000, 10,000
289	1747	0.8	1.7	2.8	none, 10,000
456	1747	0.8	2.1	3.4	none, 10,000
416	1747	0.8	2.5	4.0	none, 10,000

Profile No. 20a

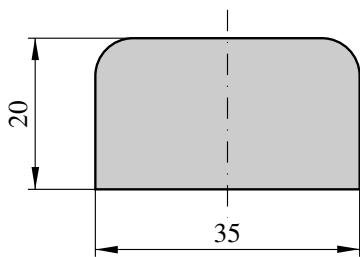

Profile No. 20

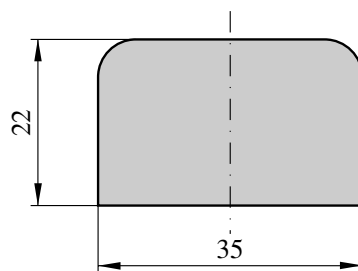

Profile No. 1746

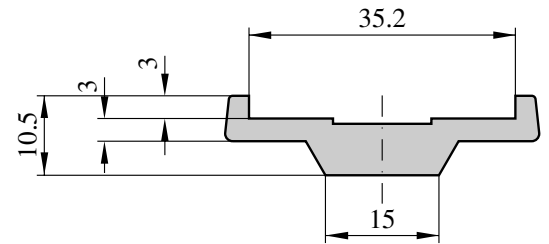

Profile No. 444

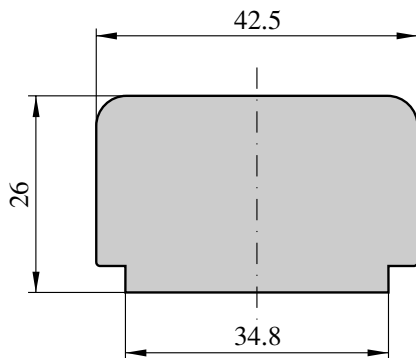

Profile No. 414

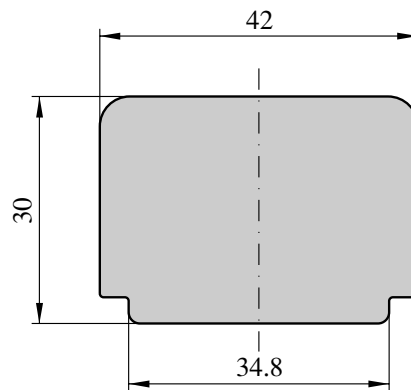

Profile No. 1744

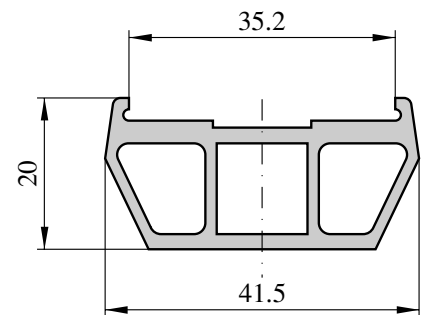

Profile No. 289, thickness 18 mm
 Profile No. 456, thickness 22 mm
 Profile No. 416, thickness 26 mm

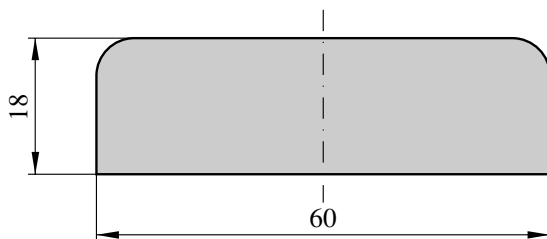

Profile No. 1747

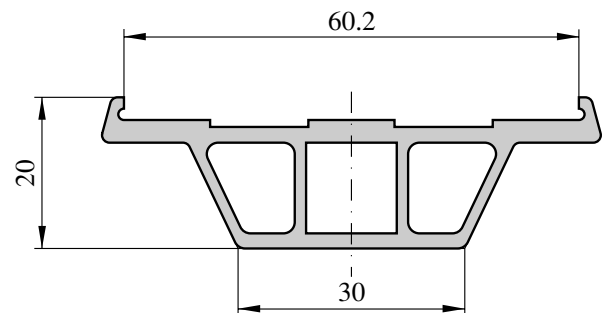

ABCS (Adhesive Bonded Carbon Strip) with Pneumatic Monitor

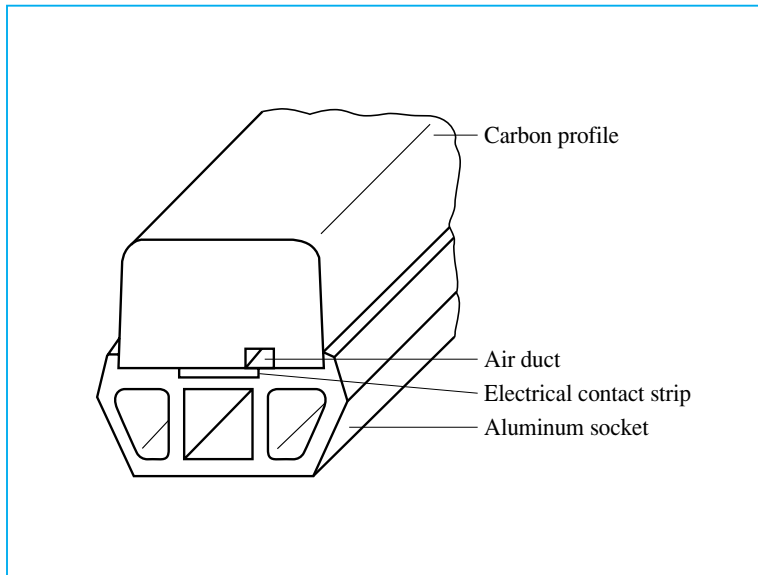

Especially for High-Speed applications the pantograph needs to lower fast and automatically, in case of carbon breakage or end of carbon life.

SBT offers a system, which operates as follows:

A sealed pressurized air duct at the underside of the carbon profile covers the whole length of the carbon strip. In case of carbon breakage, or excessive carbon wear, a leak will develop, causing the air to escape and automatically lower the pantograph.

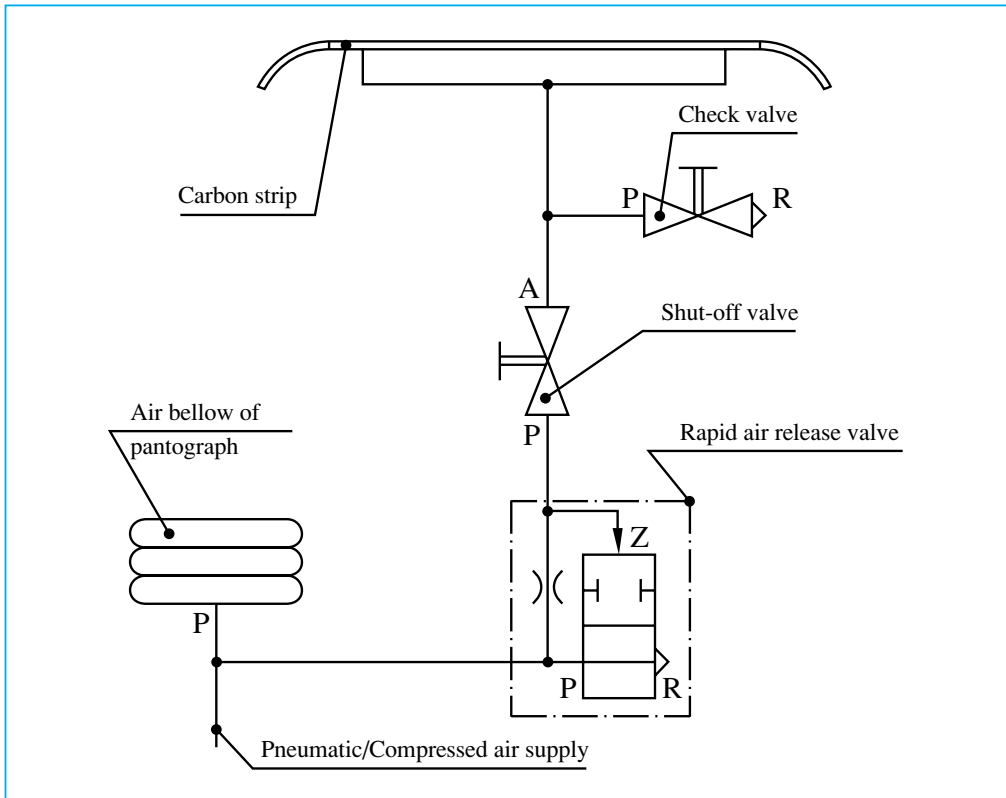

As long as a pneumatic supply is available on a vehicle, an integration of this particular monitoring system can be incorporated into any SBT adhesive bonded carbon strip.

Pantograph Contact Pressure Gauge – KM 11

The contact pressure of a pantograph, in its entire range of operation, is an important parameter, which has a direct effect on the life of consumable parts: e.g. carbon current collector strips, and in particular, the catenary.

SBT – Schunk Bahntechnik GmbH – therefore has incorporated into their product line the mobile gauge KM 11, which can measure, and at the same time register, the static contact pressure of a pantograph. This can be done while being serviced on the ground, or while being mounted on top of the roof of the vehicle.

This gauge has universal applications, and can be utilized for single arm or diamond shape pantographs, on light rail vehicles or high speed trains alike.

Due to its extreme simple measuring procedure, and providing at the same time a service record, gauge KM 11 should be part of the standard equipment of any transit company.

Description:

The gauge is mounted to the base frame of the pantograph, and the tension rope is fastened to the spindle of the pantograph head. The measuring procedure can be seen in figure 1. The electric motor drive assures a constant up or downward motion of the pantograph (0.1 m/sec.), and at the same time propels the recording drum, which registers the tension on a graph (see figure 2).



Fig. 1

Technical Data

Measuring Range:	40 N – 120 N (9 lbs. – 27 lbs.)
Measuring Accuracy:	5 %
Lifting-/Lowering Speed:	0.1 m/sec. (4 inches/sec.)
Max. Operating Height:	3.3 meters (10.8 ft.)
Weight:	20.3 kp (45 lbs.)
Dimensions (L x W x H):	260 x 300 x 340 mm (10.25 x 12.0 x 13.4 in.)
Drive Motor:	220 VAC, 120 Watts, optional 110 VAC

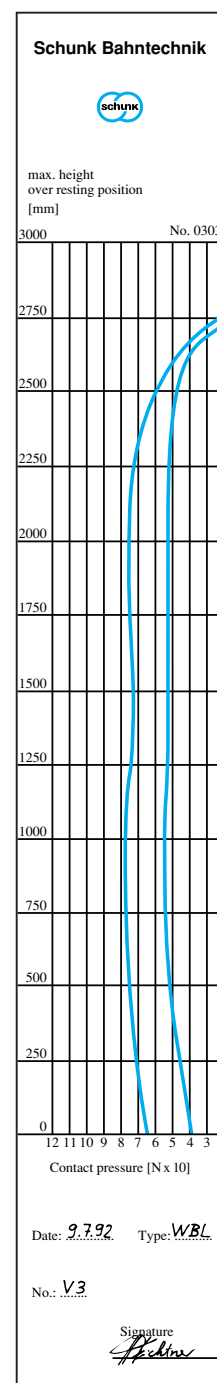

Fig. 2

Current Collection with Schunk – worldwide

Germany

Schunk Kohlenstofftechnik GmbH
Postfach 10 09 51, 35339 Giessen
Rodheimer Strasse 59, 35452 Heuchelheim
Tel. (06 41) 6 08-0, Fax (06 41) 6 08-12 23

Schunk Metall u. Kunststoff GmbH
Hauptstrasse 97
35435 Wettenberg
Tel. (06 41) 8 03-0, Fax (06 41) 8 03-1 39

Schunk Motorensysteme GmbH
Industriepark 7
27777 Ganderkesee
Tel. (0 42 22) 43-0, Fax (0 42 22) 43-21

Europe

Schunk Nordiska AB
Box 34, S-360 73 Lenhovda
Tel. (4 74) 2 95 00, Fax (4 74) 2 04 55

Schunk UK Ltd.
Richardshaw Drive
GB-Pudsey West Yorkshire LS 28 6 Q R
Tel. (1 13) 2 56 72 38, Fax (1 13) 2 55 20 17

Schunk Benelux B.V.
Jufferstraat 10, NL-3011 XM Rotterdam
Tel. (0 10) 4 14 47 66, Fax (0 10) 4 11 31 10

Schunk Benelux N.V.
Brouwersvliet 23, B-2000 Antwerpen
Tel. (3) 2 33 80 71, Fax (3) 2 25 12 76

Schunk Electrographite S.à.r.l.
78-82, Rue Alfred Déquéant, B.P. 717
F-92007 Nanterre Cedex
Tel. (1) 41 19 52 52, Fax (1) 41 19 52 50

Schunk Iberica S.A.
Sagunto, 6. Apartado 52
E-28320 Pinto (Madrid)
Tel. (91) 6 91 25 11/61, Fax (91) 6 91 49 44

Schunk Portugal Lda
Av. Bombeiros Voluntários 72 C
P-1495 Aljés/Lisboa
Tel. (21) 4 10 49 75, Fax (21) 4 10 50 36

Schunk Romania SRL
Calea Dorobantilor Nr. 172, bl 16,
sc. 1, ap. 80, sect. 1, RO-71232 Bucuresti
Tel. (1) 2 31 08 50, Fax (1) 2 30 17 09

Hoffmann & Co., Elektrokohle AG
Au 62
A-4823 Steeg
Tel. (61 35) 4 00-0, Fax (61 35) 4 00-10 or 12

Schunk AG
Postfach 40, Seestrasse 240
CH-8802 Kilchberg
Tel. (1) 716 46 46, Fax (1) 716 46 16

Richard AG
Hauptstrasse 115
CH-4853 Murgenthal
Tel. (0 62) 9 17 10 40, Fax (0 62) 9 17 10 49

Schunk Wien Ges.m.b.H.
Ober-Laaer-Strasse 316, A-1232 Wien
Tel. (1) 6 16 68 07/08, 6 16 73 20
Fax (1) 6 16 68 07-36

Schunk Italia S.r.l.
Via Murri 22 – 28, I-20013 Magenta (MI)
Tel. (02) 97 21 90-1, Fax (02) 97 29 14 67

Schunk Praha spol. s.r.o.
vyrubni zavod Plzen
Skladova ul.c. 7, CZ-31705 Plzen
Tel. (19) 7 45 41 11
Fax (19) 7 45 54 98

Sirma Elektrik Kömürleri San. ve Tic. A.Ş.
Perembe Pazar Cad. 41/2
T-80004 Karaköy-Istanbul
Tel. (2 12) 244 53 59, Fax (2 12) 249 43 20

Asia

Schunk United Carbon Co. Ltd.
7/8 Moo 11 Soi Kumrasi
Ramkamhang Road
Minburi, Bangkok 10510, Thailand
Tel. (2) 5 17-62 23-6, Fax (2) 5 17-62 67

Schunk General Carbon Ltd.
Unit 1004, Tsuen Wan Industrial Center
220 Texaco Road
Tsuen Wan N.T., Hong Kong
Tel. (2) 4 08 66 88, Fax (2) 4 07 34 09

Schunk General Carbon (Panyu) Co., Ltd.
Weichongcunm, Zhongcunzhen
511495 Panyu, Guangzhou
PRC-China
Tel. (20) 84 71-47 61, Fax (20) 84 71-46 90

Seung Lim Carbon Metal Co., Ltd.
737-2 Wonsi-Dong
Ansan-City, Kyunggi-Do
Korea
Tel. (3 45) 4 91-27 22, Fax (3 45) 4 91-27 26

Schunk Metal & Carbon (India) Private Limited
No. 529, Sadananda Nagar
NGEF Layout, Bangalore-560 038
India
Tel. (80) 8 51 67 13, Fax (80) 5 24 21 45

Schunk Carbon (M) Sdn. Bhd.
19, Jalan Serindit 2
Bandar Puchong, Jaya
47100 Puchong, Selangor Darul Ehsan,
Malaysia
Tel. (3) 4 32-29 70, Fax (3) 4 32-29 15

Australia

Schunk (Australia) Pty. Ltd.
P.O. Box 2387
Ringwood North,
VIC 3134 Australia
Tel. (3) 9753-3588, Fax (3) 9753-3599

America

Schunk Graphite Technology LLC
W 146 N9300 Held Drive
USA-Menomonee Falls, Wisconsin 53 051-1643
Tel. (2 62) 2 53 87 20, Fax (2 62) 2 55 13 91

United Knitting Machine Co., Inc.
Gehman Rd. & Transit Way, P.O. Box 309
Kulpsville, PA 19443/USA
Tel. (1) 21 52 56 48 00, Fax (1) 21 52 56 48 14

Schunk Electro Carbón, S.A. de C.V.
Acueducto del Alto Lerma No. 6,
Zona Industrial, Ocoyoacac, Edo. de Mexico
C.P. 52740
Tel. (7 28) 7 66-11-14, Fax (7 28) 7 66-15

Schunk do Brasil Ltda.
Caixa Postal 635, Estrada do Embu No. 2777
06713-901 Bairro Moinho Velho-Cotia, SP
Tel. (11) 79 22-85 00, Fax (11) 4 92-56 59



10.04e



Schunk Bahntechnik GmbH
Aupoint 23
A-5101 Bergheim bei Salzburg

Phone (06 62) 45 92 00
Telefax (06 62) 45 92 00-1
E-Mail: office@schunk-group.at

Schunk Bahntechnik GmbH